



LEHENGOTAK, S.A.

Art. 5800 ACTUADOR NEUMATICO DE ALUMINIO – Gen-Air

Art. 5800 PNEUMATIC ACTUATORS IN ALUMINIUM – Gen-Air

Características	Features
<p>1. Los actuadores neumáticos con piñón y cremallera GENEBRE, S.A., proyectados con un diseño compacto, efectúan un par lineal en toda su carrera.</p> <p>2. Cuerpo de aluminio extruido según ASTM 6005, con anodizado como protección a la corrosión interna y externa, con fino acabado interno del cilindro para obtener un bajo coeficiente de fricción.</p> <p>3. Utilizan el mismo cuerpo y cabezal tanto en las configuraciones de simple efecto y doble efecto.</p> <p>4. Toda la serie de actuadores han sido proyectados según las normas Namur VDI/VDE 3845 e ISO 5211, que permiten el montaje directamente de electro válvulas, caja de interruptores, posicionadores, etc.</p> <p>5. El ángulo estándar de rotación es de 90°; están disponibles bajo pedido las versiones a 120°, 135°, 150° y 180°. Para el modelo 15 y unidades superiores está prevista la posibilidad de registros de +/- 10° en ambas direcciones de apertura y de cierre.</p> <p>6. Indicadores de posición externos en la dotación estándar.</p> <p>7. La altura del piñón (NAMUR H = 30) permite efectuar acciones manuales de emergencia sin interferir con el indicador.</p> <p>8. La presión a la cual es posible trabajar está comprendida entre 2 y 10 bar. Para accionar el actuador es posible utilizar aire comprimido filtrado, seco o mejor lubricado.</p> <p>9. La conexión hembra del piñón es, en la configuración estándar, un Doble Cuadrado.</p> <p>10. Los muelles, construidos en acero especial con recubrimiento anticorrosivo, están pre montados solamente con material tecno-polímero.</p> <p>11. Todas las unidades están lubricadas en fase de montaje, con grasa sin base de silicona.</p> <p>12. Todos los tornillos y tuercas externas son de acero inoxidable.</p>	<p>1. The pneumatic actuators with rack & pinion GENEBRE, S.A., projected with a compact design, they make a lineal couple in their entire career.</p> <p>2. Extruded aluminium ASTM6005 body with internal surface having honed cylinder for longer life and low friction coefficient, and both internal and external corrosion protection treated with anodized.</p> <p>3. They use the same body and so many bolsters in the configurations of spring return and double effect.</p> <p>4. The whole actuators series has been projected according to the norms Namur VDI/VDE 3845 and ISO 5211 that allow the assembly directly of solenoid valves, box of switches, positioners, etc.</p> <p>5. The standard angle of rotation is of 90°; they are available under order the versions at 120°, 135°, 150° and 180°. For the pattern 15 and superior units the possibility of registrations is foreseen of +/- 10° in both opening addresses and of closing.</p> <p>6. External indicators open / closed in the standard endowment.</p> <p>7. The height of the pinion (NAMUR H = 30) it allows to make manual actions of emergency without interfering with the indicator.</p> <p>8. The pressure to which is possible to work is understood between 2 and 10 bar. To work the actuator it is possible to use air compressed filtrate, dry or better lubricated.</p> <p>9. The female of the pinion drive is, in the standard configuration, a Square Double.</p> <p>10. Epoxy coated special steel springs are preloaded with non-metallic materials. The stainless steel end cap fasteners are extra log to allow for spring relaxation. All parts are corrosion resistance.</p> <p>11. All the units are lubricated in assembly phase, with fat without silicone base.</p> <p>12. All the screws and external nuts are made of stainless steel.</p>



LEHENGOTAK, S.A.



LEHENGOAK, S.A.

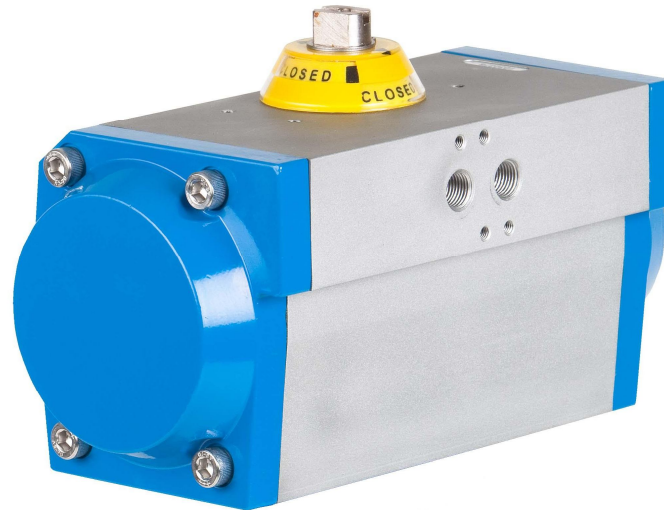

CONDICIONES DE TRABAJO

- 1. Fluidos de accionamiento**
Aire seco o lubricado, Gases no corrosivos.
- 2. Presión de suministro de aire**
Doble acción: 2 ÷ 10 Bar;
Simple acción: 2 ÷ 10 Bar
- 3. Temperatura de funcionamiento**
Standard: de -20°C +80°C
Baja / Alta temperatura: -50°C +150°C (bajo pedido)
- 4. Ajuste del Recorrido**
Tiene un rango de ajuste de $\pm 10^\circ$ para la rotación en 90°
- 5. Lubricación**
No necesita acrecentar el lubricante en condiciones normales de trabajo
- 6. Aplicación**
Cualquiera interior o exterior
- 7. Presión máxima**
La presión máxima de entrada debe ser de 10 bar

OPERATING CONDITIONS

- 1. Operating media**
Dry or lubricated air, the non-corrosive gases.
- 2. Air supply pressure**
Double acting: 2 ÷ 10 Bar;
Spring return: 2 ÷ 10 Bar
- 3. Operating temperature**
Standard: -20°C +80°C
Low / High temperature: -50°C +150°C (available on request)
- 4. Travel adjustment**
Have adjustment range of $\pm 10^\circ$ for the rotation at 90°
- 5. Lubrication**
Under normal operating condition, need not accrete lubricant
- 6. Application**
Either indoor or outdoor
- 7. Highest pressure**
The maximum input pressure is 10 Bar



LEHENGOAK, S.A.



LEHENGOMAK, S.A.

DESPIECE y RECAMBIOS

ASSEMBLE AND PARTS

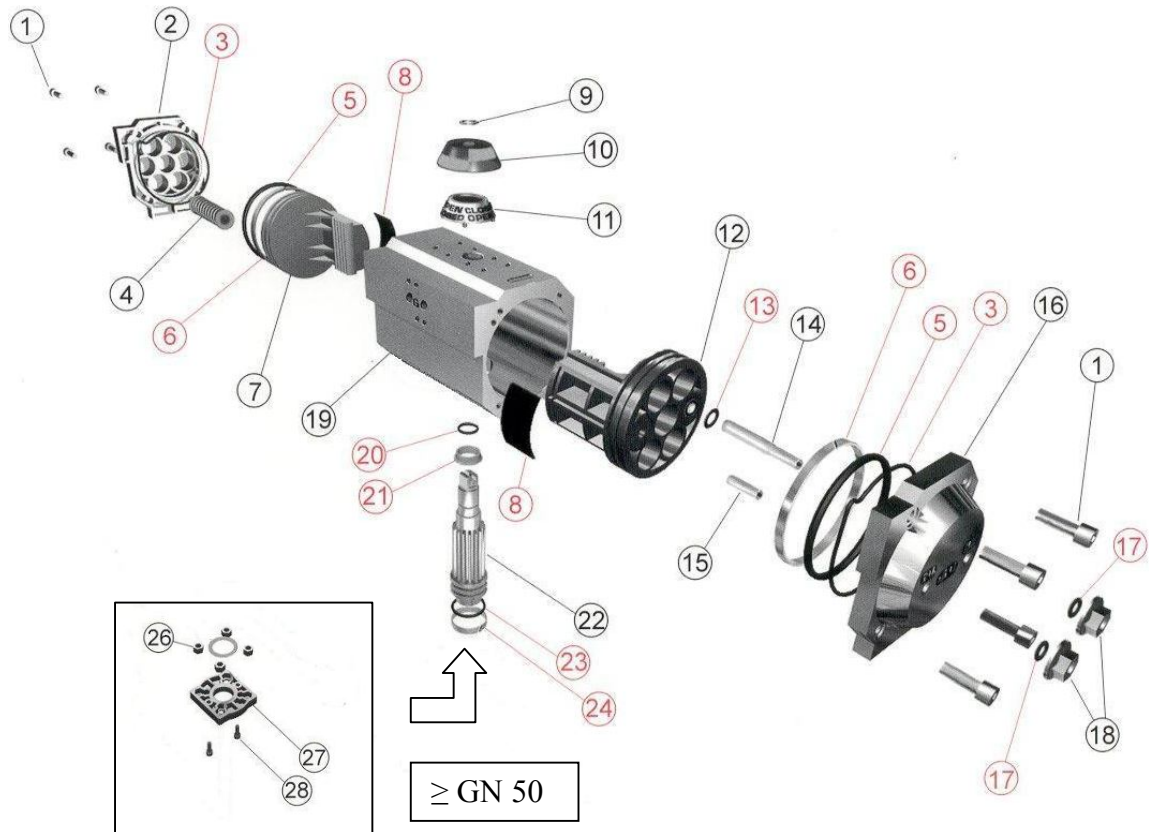

Nº	Denominación / Name		Material / Material	
1	Tornillo cabezales	End cap screw	Acero INOX AISI 304	AISI 304 steel
2	Cabezal izquierdo	Left end cap	Aluminio fundido a presión UNI 5076	Die cast aluminium UNI 5076
3	O-ring cabezal	End cap o-ring	NBR 70 Shore	NBR 70 Shore
4	Cartucho muelles	Spring cartridge	Acero para muelles	Spring steel epoxyd coated
5	O-ring piston	Piston o-ring	NBR 70 Shore	NBR 70 Shore
6	Anillo guía	Guide ring	Tecno – polímero	Techno - polymer
7	Pistón izquierdo	Left piston	Aluminio fundido a presión UNI 5076	Die cast aluminium UNI 5076
8	Patín pistón	Piston Skate	Tecno – polímero	Techno - polymer
9	Seeger indicador	Indicator snap ring	Acero INOX AISI 304	AISI 304 steel
10	Indicador (parte móvil)	Indicator (rotating part)	Tecno – polímero	Techno - polymer
11	Indicador (parte fija)	Indicator (fix part)	Tecno – polímero	Techno - polymer
12	Pistón derecho	Right piston	Aluminio fundido a presión UNI 5076	Die cast aluminium UNI 5076
13	O-ring para el eje de regulación	Regulation o – ring	NBR 70 Shore	NBR 70 Shore
14	Eje de regulación interna	Internal regulation screw	Acero INOX AISI 304	AISI 304 steel
15	Prisionero de regulación externa	Stop bolt	Acero INOX AISI 304	AISI 304 steel



LEHENGOMAK, S.A.



16	Cabezal derecho	Right end cap	Aluminio fundido a presión UNI 5076	Die cast aluminium UNI 5076
17	O-ring tuerca registro	Stop bolt nut o - ring	NBR 70 Shore	NBR 70 Shore
18	Tuerca de registro	Stop bolt nut	Acero INOX AISI 304	AISI 304 steel
19	Cuerpo actuador	Actuator body	Aluminio extrusionado ASTM B210 (6063)	Extruded aluminium ASTM B 210 (6063)
20	O-ring piñón superior	Upper pinion o - ring	NBR 70 Shore	NBR 70 Shore
21	Anillo guía piñón superior	Upper pinion bearing	Tecno - polímero	Techno - polymer
22	Piñón	Pinion	Acero SAE 11L14 niquelado ASTM B 733	SAE 11L 14 nickel plated ASTM B 733
23	O-ring piñón inferior	Lower pinion o-ring	NBR 70 Shore	NBR 70 Shore
24	Anillo guía piñón inferior	Lower pinion bearing	Tecno - polímero	Techno - polymer
26	Tuercas *	Nuts*	Acero INOX AISI 304	AISI 304 steel
27	Brida*	Flange*	Aluminio fundido a presión UNI 5076	Die cast aluminium UNI 5076
28	Tornillos de fijación brida*	Flange screws*	Acero INOX AISI 304	AISI 304 steel

PIEZAS QUE COMPONEN EL KIT DE REPARACION / REPAIR KIT PARTS.

Notas / Notes: * solamente modelo GN 50 y mayores / Model \geq GN 50 Only

Esquema de Funcionamiento

Functional Diagram

Doble Efecto / Double Acting

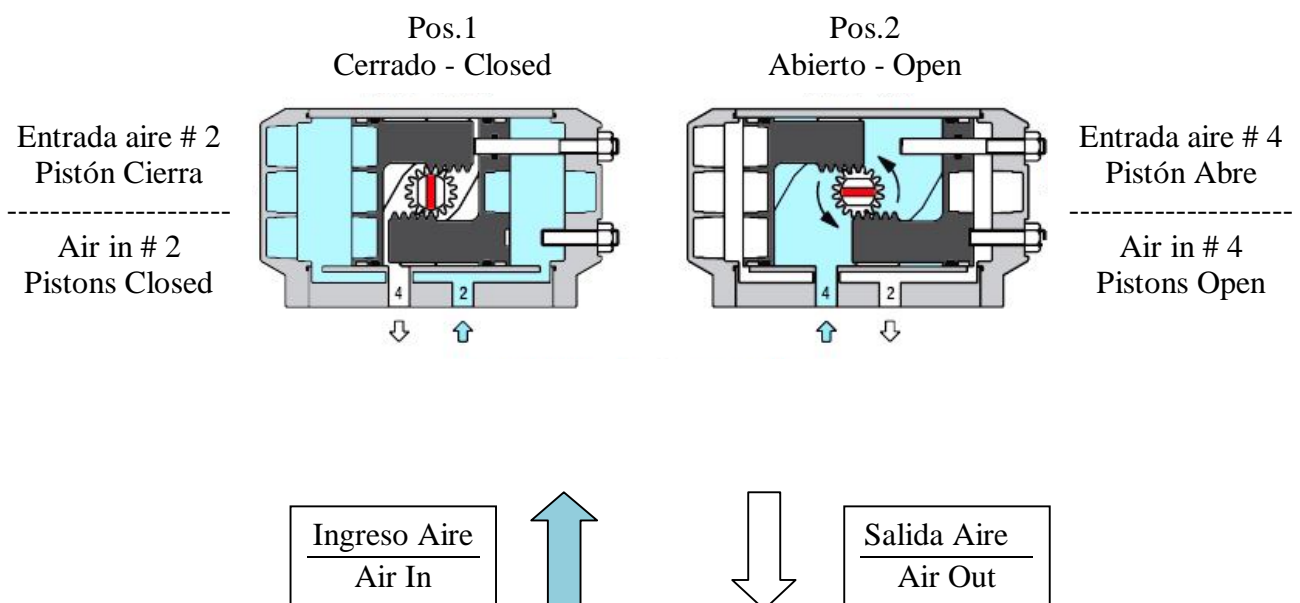



Simple Efecto / Spring Return

Fase de Apertura – Opening Phase

Pos.2
START

Pos.2
END

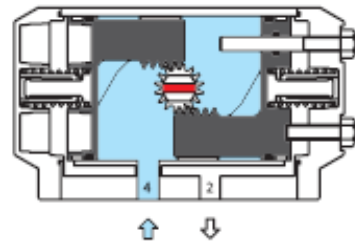
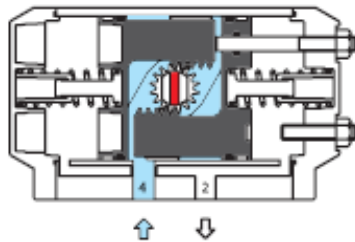

Entrada aire # 4 = Pistón Abre

Air in # 4 = Pistons Open

Fase de Cierre – Closing Phase

Pos.1
START

Pos.1
END

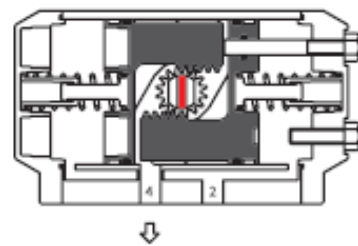
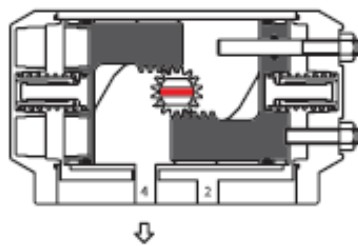

Sin aire = Pistón Cierra (mediante los muelles)

Without Air = Pistons Closed (Spring Release)

Ingreso Aire
Air In



Salida Aire
Air Out





LEHENGOMAK, S.A.

DIMENSIONES

DIMENSIONS

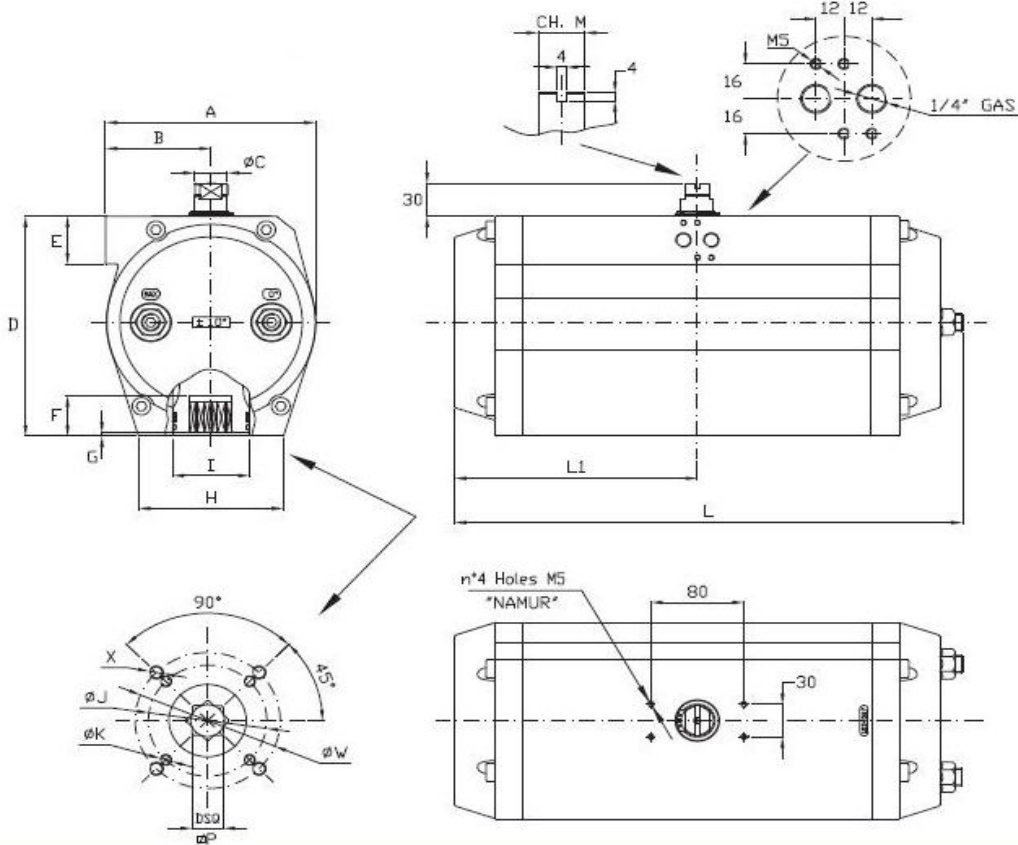

Modelos / Models	Dimensiones / Dimensions (mm)											
	DSQ	ISO 5211	A	B	D	E	F	G	H	Ø I	L	L1
GN 05	11	F03/F05	67	40	71	45	12.5	1.5	47	22	119	59.5
GN 15	14	F05/F07	81	47	81	45	19	2	62	33	175	82.5
GN 17	14	F05/F07	81	47	81	45	19	2	62	33	207	98.5
GN 20	17	F05/F07	96	54	98	45	19	2	76.5	35	186	88.5
GN 25	17	F05/F07	96	54	98	45	23	2	76.5	40.5	248	119.5
GN 30	17	F05/F07	114	62	117	45	23	2	90.5	40.5	241	115
GN 35	22	F07/F10	131	66	154	45	30	3	95.5	40.5	261	123
GN 40	22	F07/F10	131	66	154	45	30	3	95.5	45	305	145
GN 45	22	F07/F10	145	73	168	45	30	3	98.5	56.5	367	175.5
GN 50	27	F10 o F12	185	93	217	45	37	3	120	50	371	180.5
GN 55	27	F10 o F12	185	93	217	45	37	3	120	50	428	209
GN 60	36	F12 o F14	235	118	274	45	50	4	140	60	454	222
GN 65	36	F12 o F14	235	118	274	45	50	4	140	60	512	251
GN 70	46	F16	332	166	332	55	64	5	160	105	597	293.5
GN 75	46	F16	332	166	332	55	64	5	160	140	687	338.5



LEHENGOMAK, S.A.



Ajuste del Recorrido / Travel adjustment

Tiene un rango de ajuste de $\pm 10^\circ$ para la rotación en 90° / Have adjustment range of $\pm 10^\circ$ for the rotation at 90°

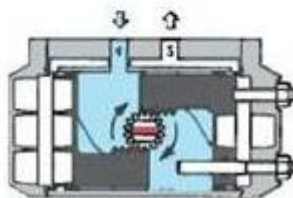
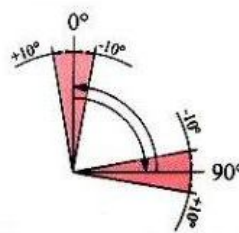
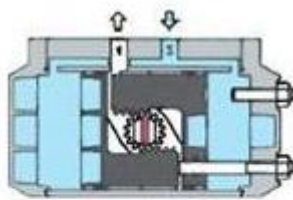
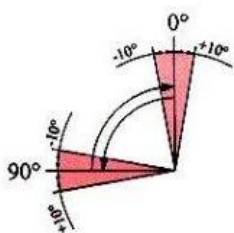

Ajuste de cierre / Adjustment Closed (0°)

Ajuste de apertura / Adjustment Open (MAX)

CONSUMO DE AIRE (Ciclo Completo)

AIR CONSUMPTION (Full Cycle)

Model	Doble Efecto Double Acting	Simple Efecto Spring Return
GN 05	0.22	0.13
GN 15	0.41	0.18
GN 17	0.55	0.25
GN 20	0.71	0.29
GN 25	1.10	0.48
GN 30	1.40	0.65
GN 35	2.45	1.20
GN 40	3.05	1.60
GN 45	4.40	1.85
GN 50	6.80	2.90
GN 55	9.00	4.10
GN 60	14.10	5.50
GN 65	16.60	7.10
GN 70	27.10	9.60
GN 75	31.40	11.70

Consumo en N. Lt. / Consumption in N. Lt. (N = Normal Presion Atmosférica / Atmospheric Pressure)





PESO (Kg)

WEIGHT (Kg)

Modelo / Type	GN 05	GN 15	GN 17	GN 20	GN 25	GN 30	GN 35	GN 40	GN 45	GN 50	GN 55	GN 60	GN 65	GN 70	GN 75
SE / SR	0.99	1.69	2.42	2.53	3.77	4.88	7.89	9.38	13.21	22.60	27	45.9	52.40	82.96	98
DE / DA	0.91	1.50	2.18	2.15	3.25	4.15	6.45	7.70	10.65	17.80	22.18	36.30	42.80	66.80	81.60

DIMENSIONADO DOBLE EFECTO

El factor de seguridad sugerido para los actuadores de Doble Efecto bajo condiciones de trabajo normales es del 20% al 35%.

Ejemplo:

- El Par necesario para la válvula es de = 100 Nm
- El Par considerando el factor de seguridad (100 + 30%) es de 130 Nm
- Presión del aire de alimentación = 6 bar

De acuerdo con la Tabla de Pares, nosotros debemos elegir el modelo más aproximado que es el **GN - 35 (193,3 Nm)**

DOUBLE ACTING SIZING

The suggested safety factor for Double Acting actuators under normal working conditions is 20%-35%.

Example:

- The torque needed by valve=100Nm
- The torque considered safety factor (100 + 30%) = 130Nm
- Air Suplí = 6 bar

According to the above Torque Table, we can choose the minimum model is: **GN- 35 (193,3 Nm)**

DIMENSIONADO SIMPLE EFECTO

El factor de seguridad sugerido para los actuadores de Simple Efecto bajo condiciones de trabajo normales es del 20% al 35%.

Ejemplo:

- El Par necesario para la válvula = 100 Nm
- El Par considerando el factor de seguridad (100 + 20%) es de 120 Nm
- Presión del aire de alimentación = 6 bar

De acuerdo con la Tabla de Pares que nos dan los actuadores de Simple Efecto, encontramos que los valores de pares del modelo **GN 45 S4 (4+4)** son:

Ejercido por aire a 0° = 251,2 Nm
 Ejercido por aire a 90° = 176,6 Nm
 Ejercido por muelles a 90° = 200,8 Nm
 Ejercido por muelles a 0° = 126,2 Nm

Todos los pares obtenidos son superiores al necesitado por la válvula

SPRING RETURN SIZING

The suggested safety factor for spring return actuator under normal working conditions is 30-50%

Example:

- The torque needed by valve = 100 Nm
- The torque consider safety factor
- (100 + 20%) = 120 Nm
- Air Supply = 6 bar

According to the table of spring return actuators' output, we find output torque of **GN 45 S4 (4+4)** are:

Air stroke 0° = 251,2 Nm
 Air stroke 90° = 176,6 Nm
 Spring stroke 90° = 200,8 Nm
 Spring stroke 0° = 126,2 Nm

All the output torque is larger than we needed.





PARES ACTUADORES DOBLE EFECTO / DOUBLE ACTING ACTUATORS TORQUES

Modelo / Model	Presión alimentación de aire (Bar) / Air supply pressure (Unit Bar)									
	2	3	4	5	5.62	6	7	8	9	10
GN 05	5.0	7.6	10.1	12.6	14.1	15.1	17.6	20.2	22.7	25.2
GN 15	11.0	16.5	22.0	27.5	30.9	33.0	38.5	44.0	49.5	55.0
GN 17	14.5	21.7	29.0	36.2	40.6	43.5	50.7	58.0	65.2	72.5
GN 20	20.0	30.0	40.0	50.0	56.5	60.0	70.0	80.0	90.0	100.0
GN 25	30.2	45.3	60.4	75.5	84.5	90.6	105.7	120.8	135.9	151.0
GN 30	40.0	60.3	80.4	100.5	112.7	120.6	140.7	160.8	180.9	201.0
GN 35	64.4	96.6	128.8	161.1	180.4	193.3	225.5	257.7	289.9	322.1
GN 40	80.6	120.9	161.2	201.5	225.7	241.8	282.2	322.5	362.8	403.1
GN 45	125.8	188.7	251.6	314.5	352.7	377.4	440.3	503.2	566.1	629.0
GN 50	181.2	271.8	362.4	453.0	509.2	543.6	634.2	724.8	815.4	906.0
GN 55	241.6	362.3	483.1	603.9	676.4	724.7	845.5	966.3	1087.1	1207.8
GN 60	366.4	549.6	732.8	916.0	1029.6	1099.2	1282.4	1465.6	1648.8	1832.0
GN 65	483.2	724.8	966.4	1208.0	1357.8	1449.6	1691.2	1932.8	2174.4	2416.0
GN 70	946.0	1419.0	1892.0	2635.0	2658.0	2838.0	3311.0	3784.0	***	***
GN 75	1268.0	1903.0	2537.0	3171.0	3564.0	3805.0	4439.0	5074.0	***	***

PARES ACTUADORES SIMPLE EFECTO / SPRING RETURN ACTUATORS TORQUES

Colocación de Muelles en Pistón derecho / *Spring Assembly Right Piston*



Colocación de Muelles en Pistón Izquierdo / *Spring Assembly Left Piston*





LEHENGOAK, S.A.

TIPO/ TYPE	Cantidad de muelles /Spring Qty	PRESIÓN DE AIRE DE ENTRADA EN BAR / AIR SUPPLY IN BAR														Spring output/ Obtenido por muelle	
		3		4		5		5.62		6		7		8		90°	0°
		0°	90°	0°	90°	0°	90°	0°	90°	0°	90°	0°	90°	0°	90°		
GN-05S	1 + 1	5.1	3.9	7.6	6.4	10.1	8.9	11.6	10.4	12.6	11.4	15.1	13.9	17.7	16.5	3.7	2.5
	2 + 2	2.6	0.2	5.1	2.7	7.6	5.2	9.1	6.7	10.1	7.7	12.6	10.2	15.2	12.8	7.4	5.0
	3 + 3	--	--	--	--	5.1	1.5	6.6	3.0	7.6	4.0	10.1	6.5	12.7	9.1	11.2	7.5
GN-15S	2 + 2	10.5	8.1	16.0	13.6	21.5	19.1	24.6	22.5	27.0	24.6	32.5	30.1	38.0	35.6	8.4	6.0
	3 + 3	7.4	3.9	12.9	9.4	18.4	14.9	21.8	18.3	23.9	20.4	29.4	25.9	34.9	31.4	12.6	9.1
	4 + 4	--	--	9.9	5.1	15.4	10.6	18.8	14.0	20.9	16.1	26.4	21.6	31.9	27.1	16.9	12.1
	5 + 5	--	--	6.9	0.9	12.4	6.4	15.8	9.8	17.9	11.9	23.4	17.4	28.9	22.9	21.1	15.1
	7 + 5	--	--	--	--	9.4	2.2	12.8	5.6	14.9	7.7	20.4	13.2	25.9	18.7	25.3	18.1
GN-17S	2 + 2	14.5	11.2	21.8	18.5	29.0	25.7	33.4	30.1	36.3	33.0	43.5	40.2	50.8	47.5	10.5	7.2
	3 + 3	10.9	6.0	18.2	13.3	25.4	20.5	29.8	24.9	32.7	27.8	39.9	35.0	47.2	42.3	15.7	10.8
	4 + 4	7.3	0.8	14.6	8.1	21.8	15.3	26.2	19.7	29.1	22.6	36.3	29.8	43.6	37.1	20.9	14.4
	5 + 5	--	--	10.9	2.9	18.1	10.1	22.5	14.5	25.4	17.4	32.6	24.6	39.9	31.9	26.1	18.1
	7 + 5	--	--	--	--	14.5	4.8	18.9	9.2	21.8	12.1	29.0	19.3	36.3	26.6	31.4	21.7
GN-20S	2 + 2	19.6	16.2	29.6	26.2	39.6	36.2	46.1	42.7	49.6	46.2	59.6	56.2	69.6	66.2	13.8	10.4
	3 + 3	14.4	9.2	24.4	19.2	34.4	29.2	40.9	35.7	44.4	39.2	54.4	49.2	64.4	59.2	20.8	15.6
	4 + 4	9.2	2.3	19.2	12.3	29.2	22.3	35.7	28.8	39.2	32.3	49.2	42.3	59.2	52.3	27.7	20.8
	5 + 5	--	--	14.0	5.4	24.0	15.4	30.5	21.9	34.0	25.4	44.0	35.4	54.0	45.4	34.6	26.0
	7 + 5	--	--	--	--	18.8	8.4	25.3	14.9	28.8	18.4	38.8	28.4	48.8	38.4	41.6	31.2
GN-25S	2 + 2	31.3	23.2	46.4	38.3	61.5	53.4	70.5	62.4	76.6	68.5	91.7	83.6	106.8	98.7	22.1	14.0
	3 + 3	24.4	12.1	39.5	27.2	54.6	42.3	63.6	51.3	69.7	57.4	84.8	72.5	99.9	87.6	33.2	20.9
	4 + 4	17.4	1.1	32.5	16.2	47.6	31.3	56.6	40.3	62.7	46.4	77.8	61.5	92.9	76.6	44.2	27.9
	5 + 5	--	--	25.5	5.1	40.6	20.2	49.6	29.2	55.7	35.3	70.8	50.4	85.9	65.5	55.3	34.9
	7 + 5	--	--	--	--	33.6	9.2	42.6	18.2	48.7	24.3	63.8	39.4	78.9	54.5	66.3	41.9
GN-30S	2 + 2	39.2	32.0	59.3	52.1	79.4	72.2	91.6	84.4	99.5	92.3	119.6	112.4	139.7	132.5	28.3	21.1
	3 + 3	28.7	17.9	48.8	38.0	68.9	58.1	81.1	70.3	89.0	78.2	109.1	98.3	129.2	118.4	42.4	31.6
	4 + 4	18.1	3.7	38.2	23.8	58.3	43.9	70.5	56.1	78.4	64.0	98.5	84.1	118.6	104.2	56.6	42.2
	5 + 5	--	--	27.7	9.7	47.8	29.8	60.0	42.0	67.9	49.9	88.0	70.0	108.1	90.1	70.7	52.7
	7 + 5	--	--	--	--	37.3	15.6	49.5	27.8	57.4	35.7	77.5	55.8	97.6	75.9	84.9	63.2
GN-35S	2 + 2	62.0	50.1	94.2	82.3	126.5	114.6	145.8	133.9	158.7	146.8	190.9	179.0	223.1	211.2	46.5	34.6
	3 + 3	44.6	26.9	76.8	59.1	109.1	91.4	128.4	110.7	141.3	123.6	173.5	155.8	205.7	188.0	69.7	52.0
	4 + 4	27.2	3.6	59.5	35.8	91.8	68.1	111.1	87.4	124.0	100.3	156.2	132.5	188.4	164.7	93.0	69.3
	5 + 5	--	--	42.2	12.6	74.5	44.9	93.8	64.2	106.7	77.1	138.9	109.3	171.1	141.4	116.2	86.6
	7 + 5	--	--	--	--	57.1	21.6	76.4	40.9	89.3	53.8	121.5	86.0	153.7	118.2	139.5	104.0
GN-40S	2 + 2	79.0	63.9	119.3	104.2	159.6	144.5	183.8	168.7	199.9	184.8	240.3	225.2	280.6	265.5	57.0	41.9
	3 + 3	58.1	35.4	98.4	75.7	138.7	116.0	162.9	140.2	179.0	156.3	219.4	196.7	259.7	237.0	85.5	62.8
	4 + 4	37.2	6.8	77.5	47.1	117.8	87.4	142.0	111.6	158.1	127.7	198.5	168.1	238.8	208.4	114.1	83.7
	5 + 5	--	--	56.5	18.6	96.8	58.9	121.0	83.1	137.1	99.2	177.5	139.6	217.8	179.9	142.6	104.7
	7 + 5	--	--	--	--	75.9	30.4	100.1	54.6	116.2	70.7	156.6	111.1	196.9	151.4	171.1	125.6
GN-45S	2 + 2	125.6	88.3	188.5	151.2	251.4	214.1	289.6	252.3	314.3	277.0	377.2	339.9	440.1	402.8	100.4	63.1
	3 + 3	94.0	38.1	156.9	101.0	219.8	163.9	258.0	202.1	282.7	226.8	345.6	289.7	408.5	352.6	150.6	94.7
	4 + 4	--	--	125.4	50.8	188.3	113.7	226.5	151.9	251.2	176.6	314.1	239.5	377.0	302.4	200.8	126.2
	5 + 5	--	--	--	--	156.7	63.5	194.9	101.7	219.6	126.4	282.5	189.3	345.4	252.2	251.0	157.8
	7 + 5	--	--	--	--	125.2	13.3	163.4	51.5	188.1	76.2	251.0	139.1	313.9	202.0	301.2	189.3
GN-50S	2 + 2	173.7	147.5	264.3	238.1	354.9	328.7	411.1	384.9	445.5	419.3	536.1	509.9	626.7	600.5	124.3	98.1
	3 + 3	124.6	85.3	215.2	175.9	305.8	266.5	362.0	322.7	396.4	357.1	487.0	447.7	577.6	538.2	186.5	147.2
	4 + 4	--	--	166.2	113.8	256.8	204.4	313.0	260.6	347.4	295.0	438.0	385.6	528.6	476.2	248.6	196.2
	5 + 5	--	--	117.1	51.6	207.7	142.2	263.9	198.4	298.3	232.8	388.9	323.4	479.5	414.0	310.8	245.3
	7 + 5	--	--	--	--	158.7	80.1	214.9	136.3	249.3	170.7	339.9	261.3	430.5	351.9	372.9	294.3
GN-55S	2 + 2	243.2	194.4	364.0	315.2	484.8	436	557.3	508.5	605.6	556.8	726.4	677.6	847.2	798.4	167.9	119.1
	3 + 3	183.6	110.5	304.0	213.3	425.2	352.1	497.7	424.6	546.0	472.9	666.8	593.7	787.6	714.5	251.8	178.7
	4 + 4	124	26.6	244.8	147.4	365.6	268.2	438.1	340.7	486.4	389.0	607.2	509.8	728.0	630.6	335.7	238.3
	5 + 5	--	--	185.3	63.4	306.1	184.2	378.6	256.7	426.8	305.0	547.7	425.8	668.5	546.6	419.7	297.8
	7 + 5	--	--	--	--	246.5	100.3	319.0	172.8	367.3	221.1	488.1	341.9	608.9	462.7	503.6	357.4
GN-60S	2 + 2	356.5	307.4	539.7	490.6	722.9	673.8	836.5	787.4	906.1	857.0	1089.3	1040.2	1272.5	1223.4	242.2	193.1
	3 + 3	260.0	186.2	443.2	369.4	626.4	552.6	740.0	666.2	812.6	735.8	992.8	919.0	1176.0	1102.2	363.4	289.6
	4 + 4	163.4	65.1	346.6	248.3	529.8	431.5	643.4	545.1	713.0	614.7	896.2	797.9	1079.4	981.1	484.5	386.2
	5 + 5	--	--	250.1	127.2	433.3	310.4	546.9	424.0	616.5	493.6	799.7	676.8	982.9	860.0	605.6	482.7
	7 + 5	--	--	153.5	6.2	336.7	189.4	450.3	303.0	519.9	372.6	703.1	555.8	886.3	739.0	726.6	579.3





LEHENGOAK, S.A.

TIPO/ TYPE	Cantidad de muelles /Spring Qty	PRESIÓN DE AIRE DE ENTRADA EN BAR / AIR SUPPLY IN BAR														Spring output/ Obtenido por muelle	
		3		4		5		5.62		6		7		8			
		0°	90°	0°	90°	0°	90°	0°	90°	0°	90°	0°	90°	0°	90°	90°	0°
GN-65S	2 + 2	489.6	404.7	731.8	649.3	972.8	890.9	1122.6	1040.7	1214.4	1132.5	1456.6	1374.1	1697.6	1615.5	317.1	235.2
	3 + 3	372.0	249.1	613.6	490.7	855.2	732.3	1005.0	882.1	1096.8	973.9	1338.4	1215.5	1580.0	1457.1	475.7	352.8
	4 + 4	254.3	90.6	495.9	332.2	737.5	573.8	887.3	723.6	979.1	815.4	1220.7	1057.0	1462.3	1298.6	634.2	470.5
	5 + 5	--	--	378.3	173.6	619.9	415.2	769.7	565.0	861.5	656.8	1103.1	898.4	1344.7	1140.0	792.8	588.1
	7 + 5	--	--	260.8	14.8	502.4	256.4	652.2	406.2	744.0	498.0	985.6	739.6	1227.2	981.2	951.6	705.6
GN-70S	2 + 2	1073.0	940.0	1546.0	1413.0	2019.0	1886.0	2312.0	2179.0	2492.0	2359.0	2965.0	2832.0	3438.0	3305.0	479.0	346.0
	3 + 3	900.0	700.0	1373.0	1173.0	1846.0	1646.0	2139.0	1939.0	2319.0	2119.0	2792.0	2592.0	3265.0	3065.0	719.0	519.0
	4 + 4	727.0	461.0	1200.0	934.0	1673.0	1407.0	1966.0	1700.0	2146.0	1880.0	2619.0	2353.0	3092.0	2826.0	958.0	692.0
	5 + 5	--	--	1026.0	694.0	1499.0	1167.0	1792.0	1460.0	1972.0	1640.0	2445.0	2113.0	2918.0	2586.0	1198.0	866.0
	6 + 6	--	--	853.0	454.0	1326.0	927.0	1619.0	1220.0	1799.0	1400.0	2272.0	1873.0	2745.0	2346.0	1438.0	1039.0
	7 + 7	--	--	--	--	1153.0	688.0	1446.0	981.0	1626.0	1161.0	2099.0	1634.0	2572.0	2107.0	1677.0	1212.0
	8 + 8	--	--	--	--	--	--	1273.0	741.0	1453.0	921.0	1926.0	1394.0	2399.0	1867.0	1917.0	1385.0
GN-75S	2 + 2	1500.0	1261.0	2134.0	1895.0	2768.0	2529.0	3161.0	2922.0	3402.0	3163.0	4036.0	3797.0	4671.0	4432.0	642.0	403.0
	3 + 3	1299.0	940.0	1933.0	1574.0	2567.0	2208.0	2960.0	2601.0	3201.0	2842.0	3835.0	3476.0	4470.0	4111.0	963.0	604.0
	4 + 4	1098.0	619.0	1732.0	1253.0	2366.0	1887.0	2759.0	2280.0	3000.0	2521.0	3634.0	3155.0	4269.0	3790.0	1284.0	805.0
	5 + 5	--	--	1530.0	933.0	2164.0	1567.0	2557.0	1960.0	2798.0	2201.0	3432.0	2835.0	4067.0	3470.0	1604.0	1007.0
	6 + 6	--	--	1329.0	612.0	1963.0	1246.0	2356.0	1639.0	2597.0	1880.0	3231.0	2514.0	3866.0	3149.0	1925.0	1208.0
	7 + 7	--	--	--	--	1761.0	925.0	2154.0	1318.0	2395.0	1559.0	3029.0	2193.0	3664.0	2828.0	2246.0	1410.0
	8 + 8	--	--	--	--	1560.0	604.0	1953.0	997.0	2194.0	1238.0	2828.0	1872.0	3463.0	2507.0	2567.0	1611.0



LEHENGOAK, S.A.